



# OPERATING INSTRUCTIONS FOR **LR67 Drilling Machine**

- 1. Machine to be operated by trained personnel.**
- 2. Instructions to be read before use.**

Hy-Ram Mansfield  
Pelham Street  
Mansfield  
Nottinghamshire  
NG18 2EY

Hy-Ram Bury  
9 Portland  
Industrial Estate  
Portland Street  
Bury  
Lancashire  
BL9 6EY

Hy-Ram Enfield  
Unit 2, Riverwalk  
Business Park  
Riverwalk Road  
Enfield  
EN3 7QN

Hy-Ram Livingston  
18 Napier Square  
Houstoun Road  
Trading Estate  
Livingston  
West Lothian  
EH54 5DG

Tel: 01623 422982  
Fax: 01623 661022

Tel: 0161 7641721  
Fax: 0161 7620577

Tel: 0208 805 8010  
Fax: 0208 805 6010

TEL: 01506 440233  
Fax: 01506 440266

# Hy-Ram LR67



## Hy-Ram LR67 Drilling Machine & Accessories

Underpressure Drilling Machine designed specifically for drilling through the Hy-Ram Hi-Flow Drilling Saddle.

Drills up to 67mm diameter with cutters available for CI, DI, A/C, steel, PE and PVC pipes. The design incorporates an 80mm flange for connecting directly onto the HI-Flow saddle. Maximum working pressure 16bar.

A pneumatic drive is also available.

Description	Application	Cutter Sizes	Flange Sizes
Hy-Ram LR67 Drilling Machine	Water Pipes – Through 80mm flange. Designed specifically for use with the Hy-Ram Hi-Flow.	57 and 67mm (standard)	80mm (standard)

Ref	Product code	Description	
	130-000111	LR67 Drilling Machine Kit	Ⓜ Ⓜ
Kit Includes			
A		LR67 Drilling Machine	
B	661-000038	Drill Spindle	
C	300-000168	Cutter Adapter 4"-12"/requires centralising disc	
D	300-000169	Cutter Adapter 3"/requires centralising disc	
E	175-000021	Anti Seize Ring	
F	130-000112	12mm Pilot Drill (Std.)	
G	270-000054	5mm Allen Key	
H	270-000053	3mm Allen Key	
I	711-000039	13mm Open Ended Spanner	
J	711-000035	36mm Open Ended Spanner	
K	711-000004	Ratchet Spanner	
L	045-000100	Strong Tool Box	



Product code	Description	Product code	Description
117-000025	67mm Standard Holesaw	130-000112	12mm Pilot Drill (Std.)
117-000039	57mm Standard Holesaw	130-000121	12mm Pilot Drill (Carbide tipped)
117-000113	67mm Carbide Holesaw	130-000185	Coupon Retaining Pilot Drill
117-000093	57mm Carbide Holesaw	300-000134	Cutter Adaptor (Coupon Retaining only)

## Pneumatic Air Wrench



Pneumatic Air Wrench



Typical Application

Product code	Description	
711-000024	Pneumatic Air Wrench (Torque 60)	Ⓜ Ⓜ
300-000072	Air Wrench Adaptor	

## Bottom Sampling Setup (for use on Bottom Sampling Hiflows 6" and under):

Product code	Description
117-000098	46mm Holesaw Cutter Std. (3" Bottom Sampling only)
117-000096	46mm Holesaw Cutter Carbide. (3" Bottom Sampling only)
130-000187	Coupon Retaining Pilot Drill (Bottom Sampling)
661-000049	Extended Spindle LR67 (Bottom Sampling)
053-000011	Extended Bridle LR67 (Bottom Sampling)
400-000057	Extended Feedscrew LR67 (Bottom Sampling)



# Hi-Flow Drilling Saddles

## The System

The Hy-Ram 'Hi-Flow' System consists of a Drilling Saddle, Flanged Riser Tube and the LR67 Drilling Machine. The system allows underpressure installation of fire hydrants onto existing mains, avoiding shutdown and subsequent recharging. It is also an ideal method of installing Flushing Points adjacent to 'normally kept shut' boundary valves. The introduction of District Meter Areas has led to the frequent use of 'normally kept shut' valves, causing problems with stationary water. Consequently the installation of flushing points is increasing, driven by the requirement for better water quality.

The system enables holes up to 67mm diameter to be cut into pressurised water mains, giving excellent flow rate characteristics. The versatility of the system will allow for other applications in the water network. The saddle can be used in the vertical or horizontal plane and now also features a unique method of taking pipe wall samples from both the top and bottom of the pipe.

## The Benefits

- Underpressure installation with no shut down
- Excellent flow rate characteristics
- Robust pipe clamp gives a rigid base for mounting accessories
- Supports the pipe material in the area of the drilled hole
- Simple and quick to install
- Substantial cost savings
- Suits CI, DI, PVC and certain AC pipes up to 12"/ DN300

## Application / Specification

- Designed for all potable water and wastewater applications up to a working pressure of 16 bar
- All materials and coatings are WRAS approved



## The Identified Uses

- Underpressure installation of a fire hydrant
- Underpressure installation of an 'OXO' type flushing point either side of a boundary valve. (In the case of both the above applications, it makes future changing of the hydrant achievable without the need to shut down)
- Taking samples from the top of the pipe wall (67mm coupon). Unique system now also available for taking pipe samples from both top and bottom of the pipe - see Double Pipe Sampling section, page 117
- Installing Quadrina nipples and oversize ferrules (1½" BSP into 4" pipe) into the main whilst alleviating the need for tapping
- Forming a by-pass for the installation of a PRV or water meter when used in the horizontal plane either side of a gate valve
- Installation of a manifold or large diameter service connection
- Underpressure access into the main, for example leak detection (Hydra phone) insertion point, CCTV insertion point, Probe insertion point, Flow meter, Chlorination point, Temperature monitor point, Chemical analysis point, Correlator point



LR67 Drilling Machine

# Hi-Flow Drilling Saddles

Hi-Flows for use on Metallic and certain AC pipes:

DN mm	DN inch	Pipe Tol. mm (OD)	L mm	H mm	Hi-Flow for Metallic/AC	Bottom Sampling for Metallic/AC	Hi-Flow for PVC	Bottom Sampling for PVC
80mm	3"	88-103	180	195	080-000064	080-000074	080-000077	080-000112
100mm	4"	114-125	180	190	080-000065	080-000075	080-000078	080-000113
125mm	5"	140-153	195	205	080-000066	080-000092	080-000079	080-000114
150mm	6"	168-180	210	210	080-000067	080-000076	080-000080	080-000115
175mm	7"	193-208	240	220	080-000068	080-000093	080-000081	080-000116
200mm	8"	219-235	270	220	080-000069	080-000086	080-000082	080-000117
225mm	9"	244-262	280	225	080-000070	080-000087	080-000083	080-000118
250mm	10"	273-290	290	225	080-000071	080-000088	080-000084	080-000119
300mm	12"	324-338	300	225	080-000072	080-000110	080-000085	080-000120

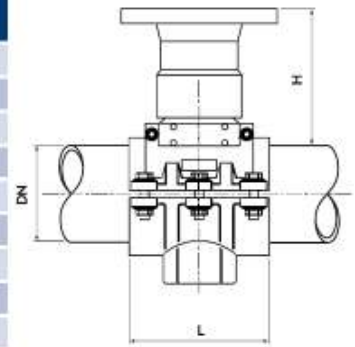

110mm and 160mm Outside Diameter Hi-Flows for use on PVC pipes:

OD mm	L mm	H mm	Product code
110mm	180	190	080-000108
160mm	210	210	080-000109

Accessories for operating Hi-Flow saddles:

Product code	Description
645-000176	Valve Plate
603-000003	Lever

## Top & Bottom Sampling of the Pipe Wall

By accessing the pipe just from the top, but taking samples from both top and bottom whilst the pipe is underpressure.

### The Benefits

This unique system enables a coupon to be taken from both the top and bottom of the pipe via two passes of the drilling spindle. Analysis of the coupons enables decisions to be made regarding whether the pipe has been previously lined and gives an indication of the condition, hence rehabilitation programs can be planned.

Normally the pipe would have to be shutdown and drained and a section cut out. The cost savings are substantial!

### The Method

The drilling saddle top half is standard, the bottom half is 'special' as it incorporates a pressure-tight boss/housing for the cutter to safely break into. The procedure is shown from figure 1.

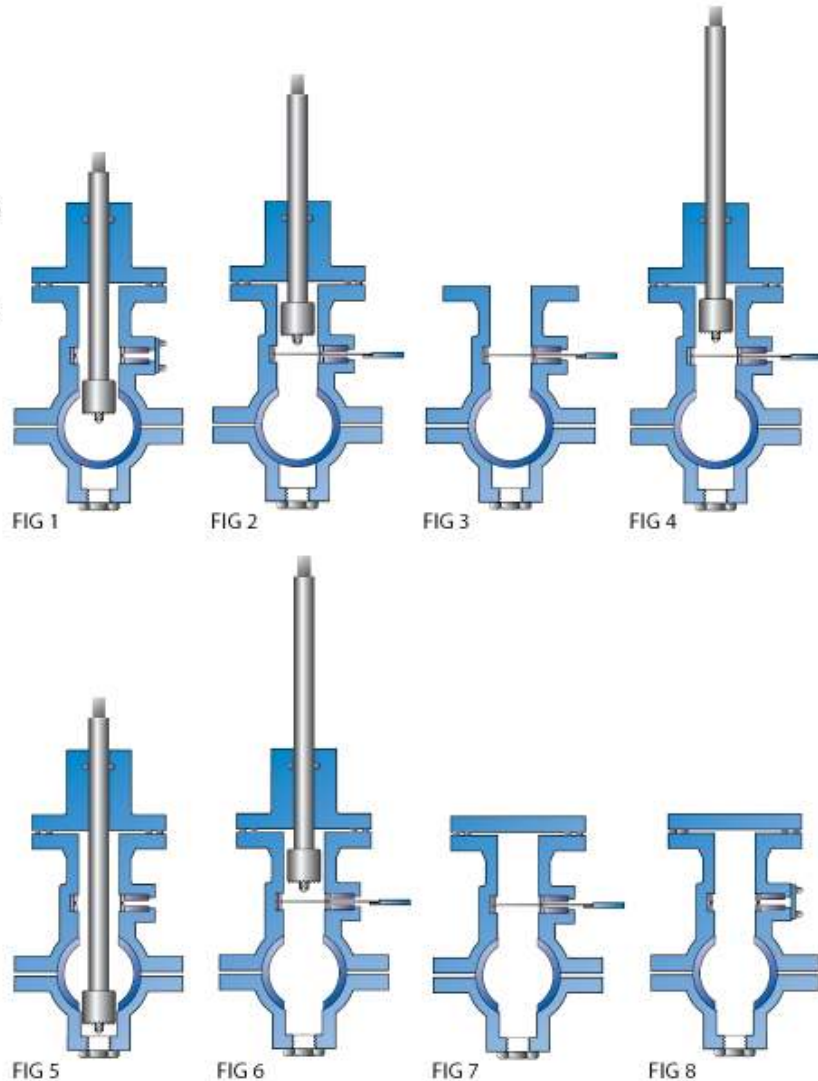



Hynam recommend that a pressure test is completed prior to the use of the LR67 Drilling Machine. The following test pumps are available for hire and purchase.

## Hydrostatic Test Pumps

**ROTHENBERGER**  
patent technology at work



### Rothenberger RP50 Pump

Pressure testing pump for carrying out hydrostatic pressure tests on water pipework systems.

**Maximum Pressure:** 60 bar.  
**Tank capacity:** 12 litres  
**Connection:** ½" BSPT

Product code	Description	
652-000015	RP50 Pressure Test Pump	Ⓜ Ⓟ
161-000161	Replacement Gauge	

**virax**



### Virax 262030 Pump

Pressure testing pump for carrying out hydrostatic pressure tests on water pipework systems.

**Maximum Pressure:** 50 bar.  
**Tank capacity:** 5 litres  
**Connection:** ½" BSPT

Product code	Description	
652-000033	Virax Pressure Test Pump	Ⓜ Ⓟ
161-000129	Replacement Gauge	

The Hy-Ram LR67 Drilling Machine is design and manufactured by Hynam Engineering Co Ltd. Hynam Engineering Co Ltd has a policy of continuous improvement in product quality and design. Hynam Engineering Co Ltd therefore reserves the right to change the specification of its models at any time, without prior notice.

### Important!

This manual forms a part of the product to which it relates. It should be kept for the life of the product. Any amendments issued by Hynam Engineering Co Ltd should be incorporated in the text. The manual should be passed to any subsequent holder or user of this product.

### Safety Information

The Hy-Ram LR67 Drilling Machine should only be used by trained and competent operators. As an operator, always ensure that you fully understand how the equipment functions and that you are fully aware of the dangers. Always wear the necessary protective clothing including adequate eye protection, hard hat, gloves, overalls, protective boots etc.



Prior to commencing work, always ensure that the drill kit is complete and fully serviceable. If in doubt replace.

### **Product Information**

The Hy-Ram LR67 Drilling Machine is designed specifically for drilling through the Hy-Ram Hi-Flow Drilling Saddle. Drills up to 67mm diameter with cutters available for CI, DI, A/C, steel and PVC pipes. The design incorporates an 80mm flange for connecting directly onto the Hi-Flow saddle. Maximum working pressure 16bar.

### **The Machine operation:**

1. Secure Hi-Flow Drilling saddle onto the Main. Ensure all bolts are tight. (There is no set torque values but the saddle should be tight onto the main).
2. Assemble Holesaw Cutter and pilot Drill onto the Drill spindle and insert Drill Spindle into the Drilling Machine.
3. Assemble drilling Machine onto the Drilling Saddle using a minimum of 4 Bolts.
4. Ensure that the Drilling Machine is assembled to the Saddle 'Square'. I.e. tighten bolts equally. After tightening ensure that the Drill Spindle rotates freely.
5. Connect Hydrostatic Test Pump to port on Drilling Machine. Open Vent Screw and bleed as water is pumped into the Saddle. After bleeding, pressure test to approx. 1 1/2 times mains pressure. Check for leakage. Disconnect Hydrostatic Test Pump.
6. Begin to Drill. Operate Ratchet Spanner and Feed Screw.

**DO NOT APPLY EXCESSIVE PRESSURE WITH THE FEEDSCREW. LET THE PILOT DRILL AND CUTTER DO THE WORK! 95% OF FAILED DRILLINGS ARE DUE TO OPERATOR ERROR. EXCESSIVE FEEDSCREW PRESSURE (RESULTING IN HOLESAW DAMAGE) IS THE MOST COMMON PROBLEM.**

7. Whilst drilling, periodically open the Thumb valve (where the Hydrostatic Test Pump was connected) to 'jet' water out. This has the effect of clearing the swarf. Also whilst drilling the operator must periodically 'feel' the cutter and 'back-off' to allow swarf to clear.
8. The operator should feel when drilling is complete and the cutter has broken through into the main. This can be confirmed by rotating the feedscrew a couple of turns without resistance. Once drilling is complete, retract the Feedscrew. Under the pressure of the water, the Drill spindle should also retract.
9. Once the operator is certain that the Cutter is fully retracted and clear of the valve plate area' remove the Valve Plate Cover. Take care not to introduce dirt to this area.
10. Chlorinate the Valve Plate, and insert. Use the lever if necessary.

11. Once fully inserted, operate the Thumb Valve on the Drilling Machine to relieve internal pressure. The Drilling Machine can then be removed.
12. Assemble Fire Hydrant/ spool pieces to the top of the Drilling Saddle. Ensure Hydrant is closed.
13. Once secure, the Valve Plate can be removed and the valve Plate Cover replaced.
14. The assembly is now complete. Take care in drying and putting the Drilling Machine

### **Certificate of Calibration.**

- This product has been inspected and tested in accordance with the ISO9001 quality control systems and procedures in place at Hynam Engineering Co Ltd.
- This product has no calibration period, periodic, safety inspections should be carried out by the operator if in any doubt please contact the manufacturer for further information

### **Decommissioning & Disposal Instructions**

*These give the instructions for decommissioning and disposal of the equipment and confirm how it is to be taken out of service safely, in respect of the Essential Health and Safety Requirements.*

- If a Hynam tool has reached the end of its useful working life and cannot be refurbished it must be disposed of through a licensed scrap or waste disposal facility. Alternatively, a reverse engineering company could be used to strip the equipment for recycling purposes.
- Disposal is the responsibility of the Customer this can also be achieved by returning the product back to the manufacturer.



### **Warranty Information.**

1. Extent of Warranty.
  - (a) Hy-Ram Engineering Co Ltd warrants to the end-user customer that its products will be free from defects in materials and workmanship, for six months after the date of purchase by the end-user customer, subject to providing proof of purchase.
  - (b) If Hy-Ram Engineering Co Ltd receives, during the warranty period, notice of a defect in product which is covered by this warranty, Hy-Ram Engineering Co Ltd shall either repair or replace the product, at its option. Any replacement product may be either new or like-new, provided that it has functionality at least equal to that of the product being replaced.

- (c) All warranty work will be carried out by Hy-Ram Engineering Co Ltd unless otherwise agreed. On-site warranty and repair or replacement services are available from authorised Hy-Ram Engineering Co Ltd service facilities world-wide.
- (d) Customers shall prepay shipping charges for products returned to Hy-Ram Engineering Co Ltd for warranty service, and Hy-Ram Engineering Co Ltd will charge for return of the products back to the customer.
- (e) This warranty statement gives the customer specific legal rights. The customer may also have other rights which vary from country to country in the world.

### **Pre-conditions for Warranty Application.**

Hy-Ram Engineering Co Ltd' warranty covers only those defects which arise as a result of normal use of the product, and this warranty shall only apply in the following circumstances:

- (a) All the instructions contained in the operating manual have been complied with
- (b) And none of the following apply:
  - (i) Improper or inadequate maintenance;
  - (ii) Physical abuse;
  - (iii) Unauthorised modification, misuse or any use not in accordance with the operating manual and good industry practice;
  - (iv) Operation outside the products specifications;
  - (v) Improper site preparation or maintenance; and
  - (vi) Faulty pipe or fittings.

### **Limitations of Warranty.**

- (a) Hy-Ram Engineering Co Ltd does not warrant the operation of any product to be uninterrupted or error free.
- (b) Hy-Ram Engineering Co Ltd makes no other warranty of any kind, whether express or implied, with respect to its products. Hy-Ram Engineering Co Ltd specifically disclaims the implied warranties of satisfactory quality and fitness for a particular purpose.
- (c) To the extent that this warranty statement is inconsistent with the law of the locality where the customer uses the product, this warranty statement shall be deemed modified by the minimum necessary to be consistent with such local law.
- (d) To the extent allowed by local law, the remedies provided in this warranty statement are the customer's sole and exclusive remedies.
- (e) This tool has been designed for the range of fittings available at the time of its design and development. Hy-Ram Engineering Co Ltd can accept NO liability for the unit's ability or otherwise to work with new or different fittings that subsequently appear in the market place.



Please complete this information and keep it safely with your proof of purchase receipt.  
You will require it for any warranty claim.

Where purchased .....

Date of purchase .....

Name & address  
Of purchaser .....

.....

.....

Type of tool .....

Serial number .....

For Service and repair please contact:

Hy-Ram Mansfield  
Pelham Street  
Mansfield  
Nottinghamshire  
NG18 2EY  
Tel: 01623 422982  
Fax: 01623 661022